

CHAPTER 3

SAMPLING AND TESTING AGGREGATES

Testing

Sieve Analysis

Aggregate gradation (sieve analysis) is the distribution of particle sizes expressed as a percent of the total dry weight. Gradation is determined by passing the material through a series of sieves stacked with progressively smaller openings from top to bottom and weighing the material retained on each sieve. Sieve numbers and sizes most often used in grading aggregates for aggregate paving mixtures are given in the table below.

Nominal Dimensions
Of U. S. Standard Sieves AASHTO M 92

Sieve Designation Alternate Inches	Standard mm	Nominal Sieve Opening inches
3	75.0	3.00
2	50.0	2.00
1 1/2	37.5	1.50
1	25.0	1.00
3/4	19.0	0.750
3/8	9.5	0.375
No. 4	4.75	0.187
No. 10	2.00	0.0787
No. 20	0.850	0.0331
No. 40	0.425	0.0165
No. 60	0.250	0.0098
No. 80	0.180	0.0070
No. 100	0.150	0.0059
No. 200	0.075	0.0029

Sieve sizes to be checked for compliance for the various mixtures are designated in the specifications. See the Road and Bridge Specifications. Gradations are expressed on the basis of the total percent passing, which indicates the total percent of aggregate by weight that will pass a given size sieve.

Some of the descriptive terms used in referring to aggregate gradation are:

- (a) Coarse aggregate – all of the material retained on the No. 10 sieve (2.00 mm).
- (b) Fine aggregate or soil mortar – all of the material passing the No. 10 (2.00 mm) sieve.

Procedure For Sieve Analysis Of Dense Graded Aggregates

Dry sieve analysis and washed sieve analysis are two methods of determining proportions of various particle sizes in a mineral aggregate. In Virginia, however, a combination of both methods is used in performing a sieve analysis on aggregates. Standard procedures for performing the sieve analysis are given in VTM-25. Regardless of the size of the aggregate, the procedure for making a sieve analysis is basically the same. The steps for this procedure are outlined as follows:

1. Obtain a representative sample of the material from a 30 to 40 lbs. (13.6 to 18.1 kg) field sample by either a sample splitter or the quartering method. (See Paragraphs (a) and (b) below.) The sample of material should be reduced to a test sample weighing not less than 5000 grams dry weight.
 - (a) **Sample Splitter** - A suitable riffle sampler or sample splitter for proportional splitting of the material which is capable of obtaining representative portions of the sample without loss of fines.
 - (b) **Quartering Method** - The following method of sample - size reduction by quartering is outlined for use when a conventional sample splitter is not available.
 - (1) Distribute a shovel full of the aggregate as uniformly as possible over a wide, flat area on a tight weave canvas or other smooth surface. Continue to distribute shovel fulls of material in layers until all the sample is used to make a wide, flat pile that is reasonably uniform in thickness and distribution of aggregate sizes. Do not permit coning of the aggregate.
 - (2) Divide the pile cleanly into equal quarters with a square-ended shovel or straight piece of sheet metal. When a canvas is used, the division may be conveniently made by inserting a thin stick (or rod) under the canvas and raising it to divide the sample equally, first into halves, then into quarters.
 - (3) Remove two opposite quarters and set aside.
 - (4) Repeat the foregoing procedure with the remaining portion of the aggregate until a test sample of desired size is obtained.
 - (5) If desired, store the portion that has been set aside for possible check testing.
2. Accurately weigh the wet sample. Record this wet weight on a moisture worksheet. This material will not only be used for the gradation test but also for the moisture test. Example - 5922 grams.
3. Dry aggregate sample thoroughly. The sample is dried to a constant weight by air-drying or by use of a drying apparatus; this sample must be dried at a temperature not exceeding 140° F (60° C).
4. To complete the required tests it will also be necessary to take a small sample from the remaining material; this sample must be dried at a temperature of no more than 140° F (60° C) . From this small sample the material passing the No. 40 (425 µm) sieve will be extracted to run Atterberg Limits.
5. After the sample that was taken for the gradation test and moisture test is dried to a constant weight and cooled, accurately weigh the dried sample. In weighing and handling the sample, extreme care must be taken to avoid any loss of material, as this will affect the accuracy of the results. Also, do not adjust the weight of the sample to an even figure, such as 5000 g, 5500 g, etc. Use the entire reduced and dried sample.
6. Record the weight of the dried sample. This weight is used for two purposes. First, it is recorded on the moisture worksheet and used to determine the percent of total moisture

in the sample and, second, it is recorded and used as the weight of the total sample for computing the gradation of the material sample splitters quartering method.

7. Calculate the moisture content in the sample. We can determine the percent of total moisture of the sample by the following formula.

$$\% \text{ Moisture} = \frac{(\text{wt. of wet mat'l}) - (\text{wt. of dry mat'l.})}{\text{wt. of dry mat'l}} \times 100$$

$$\text{wt. of wet mat'l} = 5922$$

$$\text{wt. of dry mat'l} = 5640$$

$$\% \text{ moisture} = \frac{(5922 - 5640)}{5640} \times 100$$

$$\% \text{ moisture} = \frac{282}{5640} \times 100$$

$$\% \text{ moisture} = .05 \times 100$$

$$\% \text{ moisture} = 5.0$$

Note: When calculating the moisture content, round answer to the nearest 0.1 percent

8. Shake the Sample in a mechanical shaker. If no clay and silt is sticking to the aggregate there is not a problem. If this is a problem buff the entire test sample. The sample is usually by a mechanical device in which a scoopful of the aggregate is placed into a metal bowl and a rotating hard rubber mull is lowered into the material removing the dust from the stone. If the total test sample is made up of hard, fairly clean material, then the buffing of the test sample can be eliminated.

Note: Prior to running a sieve analysis for either coarse or fine aggregates, using a mechanical shaker, the shaker should be calibrated annually as outlined in VCM-20.

This calibration procedure allows the technician to determine if the mechanical shaking time is adequate. First, run the sample through the mechanical shaker for a predetermined amount of time, weigh each individual sieve, re-shake using hand-held sieves, re-weigh. Calculate the percent of the total sample passing through each sieve during hand sieving. If not more than 0.5% of the total sample passes any sieve during hand sieving, the time of sieving is adequate.

9. Separate the + No. 10 (+ 2.00 mm) (coarse) portion of the test sample into individual sizes using large sieves mounted in frames. These sieves are arranged with the more coarse sieve at the top 3 inch (75 mm); each sieve below is finer; and the finest sieve, a + No. 10 (2.00 mm) is at the bottom. It will take approximately seven to ten (10) minutes of shaking to separate the material.

10. Weigh and record the weights of the + No. 10 (+ 2.00 mm) material retained on each sieve. Suppose, upon examination of the sieves, that the first sieve we found material retained on was the 1 inch (25.0 mm) sieve. The material is carefully removed, placed on the balance and the weight recorded on the 1 inch (25.0 mm) under grams retained. This material is then removed from the balance and the next sieve examined for material retained. The material from the next sieve in this example the 3/4 inch (19.0 mm) sieve is carefully removed and placed on the balance and the weight recorded on the 3/4 inch (19.0 mm) under grams retained. This procedure is done for each successive sieve.

MECHANICAL ANALYSIS OF TOTAL SAMPLE				MECHANICAL ANALYSIS OF SOIL MORTAR			
SIEVE SIZES	GRAMS RETAINED	PERCENT RETAINED	PERCENT PASSING	SIEVE SIZES	GRAMS RETAINED	PERCENT RETAINED	PERCENT PASSING
63.0 mm (2 ½)				63.0 mm (2 ½)			
50.0 mm (2)				50.0 mm (2)			
37.5 mm (1 ½)				37.5 mm (1 ½)			
25.0 mm (1)	1155			25.0 mm (1)			
19.0 mm (3/4)	470			19.0 mm (3/4)			
9.50 mm (3/8)	860			9.50 mm (3/8)			
4.75 mm (4)	540			4.75 mm (4)			
2.0 mm (10)	445			2.0 mm (10)			
.850 mm (20)				.850 mm (20)			
.425 mm (40)				.425 mm (40)			
.250 mm (60)				.250 mm (60)			
.180 mm (80)				.180 mm (80)			
.150 mm (100)				.150 mm (100)			
.075 mm (200)				.075 mm (200)			
Total	5640			Total	166.1		

11. Obtain a representative sample of the material passing the No. 10 (2.00 mm) sieve (fine material). The material passing the No. 10 (2.00 mm) sieve is thoroughly mixed and, using a small sample splitter, is reduced until a fine gradation sample weighing between 125 - 200 grams is obtained.
12. Accurately weigh the reduced fine gradation sample. Again, care must be exercised in weighing and handling the sample, as any loss of material will affect the accuracy of the results. Use the entire reduced sample.
13. Record the weight of the fine gradation sample. This weight is recorded and used as the total weight for computing the gradation of the soil mortar. The weight should be recorded to the nearest 0.1 gram.

MECHANICAL ANALYSIS OF TOTAL SAMPLE				MECHANICAL ANALYSIS OF SOIL MORTAR			
SIEVE SIZES	GRAMS RETAINED	PERCENT RETAINED	PERCENT PASSING	SIEVE SIZES	GRAMS RETAINED	PERCENT RETAINED	PERCENT PASSING
63.0 mm (2 ½)				63.0 mm (2 ½)			
50.0 mm (2)				50.0 mm (2)			
37.5 mm (1 ½)				37.5 mm (1 ½)			
25.0 mm (1)	1155			25.0 mm (1)			
19.0 mm (¾)	470			19.0 mm (¾)			
9.50 mm (3/8)	860			9.50 mm (3/8)			
4.75 mm (4)	540			4.75 mm (4)			
2.0 mm (10)	445			2.0 mm (10)			
.850 mm (20)				.850 mm (20)	36.9		
.425 mm (40)				.425 mm (40)	26.6		
.250 mm (60)				.250 mm (60)	15.9		
.180 mm (80)				.180 mm (80)	7.8		
.150 mm (100)				.150 mm (100)	5.8		
.075 mm (200)				.075 mm (200)	19.8		
Total	5640			Total	166.1		

14. Place the fine gradation material on a No. 200 (75 µm) sieve and gently wash by passing running water through the sample. When the wash water passing through the sample is clear, the sample is considered clean. The washed material is then transferred to a drying dish and dried at 230 ± 9° F (110 ± 5° C).
15. Separate the fine gradation -10 (2.00 mm) material into individual sizes using the standard 8 in. (200 mm) diameter sieves. The sieves normally used are: No. 20 (850µm), No. 40 (425 µm), No. 60, (250 µm), No. 80 (180 µm), No. 100 (150 µm), and No. 200 (75 µm) . These sieves are arranged with the more coarse sieve at the top; each sieve below is finer; and the finest sieve, a No. 200 (75 µm), is at the bottom. A pan is placed below to retain any fine material that may pass this sieve.

The dried sample is placed on the top sieve, and the entire nest of sieves is placed in a shaker that produces a circular and tapping motion, or in other approved shaking devices. This motion assists gravity in settling the individual aggregate particles on the sieve which will properly identify the size of that particular particle.

Note: Prior to running a sieve analysis for either coarse or fine aggregates, using a mechanical shaker, the shaker should be calibrated annually as outlined in VCM-20.

This calibration procedure allows the technician to determine if the mechanical shaking time is adequate. First, run the sample through the mechanical shaker for a predetermined amount of time, weigh each individual sieve, re-shake using hand-held sieves, re-weigh. Calculate the percent of the total sample passing through each sieve during hand sieving. If not more than 0.5% of the total sample passes any sieve during hand sieving, the time of sieving is adequate. (See VCM-20)

Virginia Calibration Method - 20

Equipment Checked: Mechanical Shakers

Purpose:

This method provides instructions for calibrating the sieving effectiveness of mechanical shakers used for size analysis of materials.

Inspection Equipment Required:

1. Balance readable to 0.01 g
2. Set of sieves representative of sieves used during testing
3. Material sample of approximately the same type and size as normal samples and which does not appreciably degrade under sieving.

Tolerance:

The mechanical shakers shall meet the requirement of AASHTO T 27 5.3 and 7.4 for aggregate, AASHTO T 88 6.2 for soils and the requirements listed below.

Procedure:

1. Check condition of shaker to ensure that it is in proper working condition with vertical or lateral and vertical motions which cause the particles to bounce and turn as to present different orientations to the sieving surface, and that sieves are held firmly during sieving operation.
2. Weigh the material sample and introduce the sample to the top sieve and set sieve time to desired time. Operate shaker.
3. Weigh the contents of sieve, hand shake the material on the same size sieve for one minute and reweigh amount retained. Repeat for each sieve.
4. Determine the weight of material which passed each sieve during hand sieving and calculate the percent of the total sample which passed each sieve during hand sieving.
5. If not more than 0.5 percent of the total sample passed any sieve during hand sieving, the time of sieving, the time of sieving is adequate. The sieving time may be reduced and the above procedure repeated until more than 0.5 percent of the total weight passes a sieve during hand sieving. At this point, the next shortest sieving time which did not have more than 0.5 percent passing a sieve may be used for routine sieve analysis.
6. If more than 0.5 percent of the total sample passes any sieve during hand sieving, increase sieving time and repeat steps 2-4 until no more than 0.5 percent passes any sieve. At this point, the time which resulted in no more than 0.5 percent passing may be used for routine sieve analysis.

16. Weigh and record the weights of the fine gradation sample No. 200 (75 μm) retained on each sieve to the nearest 0.1 gram. Suppose upon examination of the sieves, that the first sieve we found material retained on was the No. 20 sieve (850 μm). The material is carefully removed, placed on the balance and the weight recorded under the “mechanical analysis of soil mortar” as grams retained for the +No. 20 sieve (+ 850 μm). This material is then removed from the balance and the next sieve examined for material retained. The material from the next sieve in this example No. 40 (425 μm) sieve is carefully removed and placed on the balance and the weight recorded on + No. 40 (+425 μm) sieve under “grams retained”. This procedure is done for each successive sieve. The weights should be recorded to the nearest 0.1 gram
17. Determine the percent retained on each sieve. Up to this point we have made entries for the weight of the total sample, weight of each +No. 10 (2.00 mm) sieve, weight of the fine gradation sample -No. 10 (2.00 mm) material and weight of each - No. 10 (2.00 mm) sieve. In order to determine the percent retained, we must divide the grams retained on each sieve by the total dry weight of the sample (5640) for the +No. 10 (2.00 mm) sieves and the total dry weight of the sample (166.1) for the -No. 10 (2.00 mm) sieves.
18. Determine the percent passing for the +No. 10 (2.00 mm) material (coarse gradation). We must first place the figure 100.0 (%) in the “percent passing” column above the screen having the first entry of grams retained. By subtracting the percent retained from the percent passing the next larger sieve, we obtain the percent passing. This process is repeated for each sieve until the percent passing the No. 10 (2.00 mm) is obtained. All calculations should be recorded to the nearest 0.1 percent.
19. Determine the percent passing for the fine gradation sample -No. 10 (2.00 mm) material). Again, we must first place the figure 100.0 (%) in the “percent passing” column above the screen having the first entry of grams retained. By subtracting the percent retained from the percent passing the next larger sieve, we obtain the percent passing. This process is repeated for each sieve until the percent passing the No. 200 (75 μm) is obtained. All calculations should be recorded to the nearest 0.1 percent.

Coarse Gradation Computation

MECHANICAL ANALYSIS OF SOIL MORTAR			
SIEVE SIZES	GRAMS RETAINED	PERCENT RETAINED	PERCENT PASSING
63.0 mm (2 ½)			
50.0 mm (2)			
37.5 mm (1 ½)			
25.0 mm (1)	1155	20.5%	
19.0 mm (3/4)	470		
9.50 mm (3/8)	860		
4.75 mm (4)	540		
2.0 mm (10)	445		
.850 mm (20)			
.425 mm (40)			
.250 mm (60)			
.180 mm (80)			
.150 mm (100)			
.075 mm (200)			
Total	5640		

MECHANICAL ANALYSIS OF SOIL MORTAR			
SIEVE SIZES	GRAMS RETAINED	PERCENT RETAINED	PERCENT PASSING
63.0 mm (2 ½)			
50.0 mm (2)			
37.5 mm (1 ½)			
25.0 mm (1)	1155	20.5%	
19.0 mm (3/4)	470	8.3%	
9.50 mm (3/8)	860	15.2%	
4.75 mm (4)	540	9.6%	
2.0 mm (10)	445	7.9%	
.850 mm (20)			
.425 mm (40)			
.250 mm (60)			
.180 mm (80)			
.150 mm (100)			
.075 mm (200)			
Total	5640		

$$\frac{\text{Grams Retained}}{\text{Total Weight}} \times 100 = (\%) \text{ Retained}$$

$$\frac{1155}{5640} \times 100 = 20.5\%$$

$$\frac{470}{5640} \times 100 = 8.3\%$$

$$\frac{860}{5640} \times 100 = 15.2\%$$

$$\frac{540}{5640} \times 100 = 9.6\%$$

$$\frac{445}{5640} \times 100 = 7.9\%$$

Fine Gradation Computation

MECHANICAL ANALYSIS OF SOIL MORTAR			
SIEVE SIZES	GRAMS RETAINED	PERCENT RETAINED	PERCENT PASSING
63.0 mm (2 ½)			
50.0 mm (2)			
37.5 mm (1 ½)			
25.0 mm (1)			
19.0 mm (¾)			
9.50 mm (¾)			
4.75 mm (4)			
2.0 mm (10)			
.850 mm (20)	36.9	22.2%	
.425 mm (40)	26.6		
.250 mm (60)	15.9		
.180 mm (80)	7.8		
.150 mm (100)	5.8		
.075 mm (200)	19.8		
Total	166.1		

MECHANICAL ANALYSIS OF SOIL MORTAR			
SIEVE SIZES	GRAMS RETAINED	PERCENT RETAINED	PERCENT PASSING
63.0 mm (2 ½)			
50.0 mm (2)			
37.5 mm (1 ½)			
25.0 mm (1)			
19.0 mm (¾)			
9.50 mm (¾)			
4.75 mm (4)			
2.0 mm (10)			
.850 mm (20)	36.9	22.2%	
.425 mm (40)	26.6	16.0%	
.250 mm (60)	15.9	9.6%	
.180 mm (80)	7.8	4.7%	
.150 mm (100)	5.8	3.5%	
.075 mm (200)	19.8	11.9%	
Total	166.1		

$$\frac{\text{Grams Retained}}{\text{Total Weight}} \times 100 = (\%) \text{ Retained}$$

$$\frac{36.9}{166.1} \times 100 = 22.2\%$$

$$\frac{26.6}{166.1} \times 100 = 16.0\%$$

$$\frac{15.9}{166.1} \times 100 = 9.6\%$$

$$\frac{7.8}{166.1} \times 100 = 4.7\%$$

$$\frac{5.8}{166.1} \times 100 = 3.5\%$$

$$\frac{19.8}{166.1} \times 100 = 11.9\%$$

MECHANICAL ANALYSIS OF TOTAL SAMPLE			
SIEVE SIZES	GRAMS RETAINED	PERCENT RETAINED	PERCENT PASSING
63.0 mm (2 ½)			
50.0 mm (2)			
37.5 mm (1 ½)			100.0
25.0 mm (1)	1155	20.5%	79.5
19.0 mm (3/4)	470	8.3%	71.2
9.50 mm (3/8)	860	15.2%	56.0
4.75 mm (4)	540	9.6%	46.4
2.0 mm (10)	445	7.9%	38.5
.850 mm (20)			
.425 mm (40)			
.250 mm (60)			
.180 mm (80)			
.150 mm (100)			
.075 mm (200)			
Total	5640		

% Passing - % Retained = % Passing

NOTE: 100% is always placed in the percent passing column one line above the screen having the first entry of grams retained.

$$100.0 - 20.5 = 79.5$$

$$79.5 - 8.3 = 71.2$$

$$71.2 - 15.2 = 56.0$$

$$56.0 - 9.6 = 46.4$$

$$46.4 - 7.9 = 38.5$$

MECHANICAL ANALYSIS OF SOIL MORTAR			
SIEVE SIZES	GRAMS RETAINED	PERCENT RETAINED	PERCENT PASSING
63.0 mm (2 ½)			
50.0 mm (2)			
37.5 mm (1 ½)			
25.0 mm (1)			
19.0 mm (3/4)			
9.50 mm (3/8)			
4.75 mm (4)			
2.0 mm (10)			100.0
.850 mm (20)	36.9	22.2%	77.8
.425 mm (40)	26.6	16.0%	61.8
.250 mm (60)	15.9	9.6%	52.2
.180 mm (80)	7.8	4.7%	47.5
.150 mm (100)	5.8	3.5%	44.0
.075 mm (200)	19.8	11.9%	32.1
Total	166.1		

% Passing - % Retained = % Passing

NOTE: 100% is always placed in the percent passing column one line above the screen having the first entry of grams retained.

$$100.0 - 22.2 = 77.8$$

$$77.8 - 16.0 = 61.8$$

$$61.8 - 9.6 = 52.2$$

$$52.2 - 4.7 = 47.5$$

$$47.5 - 3.5 = 44.0$$

$$44.0 - 11.9 = 32.1$$

20. Determine the percent retained for the -No. 10 (2.00 mm) material of the total sample. By multiplying the percent passing the No. 10 (2.00 mm) of the total sample by the percent retained on each of the sieves of the fine gradation -No. 10 (2.00 mm) sample and then dividing by 100 , we can calculate the percent retained on each sieve of the -No. 10 (2.00 mm) material for the total sample.

$\% \text{ Passing (No. 10)} \times \% \text{ Retained Soil Mortar} = \% \text{ Retained Total Sample}$

$38.5 \times 22.2 = 854.7 \div 100 = 8.54 \quad 8.5\%$
 $38.5 \times 16.0 = 616.0 \div 100 = 6.16 \quad 6.2\%$
 $38.5 \times 9.6 = 369.6 \div 100 = 3.69 \quad 3.7\%$
 $38.5 \times 4.7 = 180.9 \div 100 = 1.80 \quad 1.8\%$
 $38.5 \times 3.5 = 134.8 \div 100 = 1.34 \quad 1.3\%$
 $38.5 \times 11.9 = 458.2 \div 100 = 4.58 \quad 4.6\%$

MECHANICAL ANALYSIS OF TOTAL SAMPLE				MECHANICAL ANALYSIS OF SOIL MORTAR			
SIEVE SIZES	GRAMS RETAINED	PERCENT RETAINED	PERCENT PASSING	SIEVE SIZES	GRAMS RETAINED	PERCENT RETAINED	PERCENT PASSING
63.0 mm (2 1/2)				63.0 mm (2 1/2)			
50.0 mm (2)				50.0 mm (2)			
37.5 mm (1 1/2)			100.0%	37.5 mm (1 1/2)			
25.0 mm (1)	1155	20.5%	79.5%	25.0 mm (1)			
19.0 mm (3/4)	470	8.3%	71.2%	19.0 mm (3/4)			
9.50 mm (3/8)	860	15.2%	56.0%	9.50 mm (3/8)			
4.75 mm (4)	540	9.6%	46.4%	4.75 mm (4)			
2.0 mm (10)	445	7.9%	38.5%	2.0 mm (10)			100.0%
.850 mm (20)		8.5%		.850 mm (20)	36.9	22.2%	77.8%
.425 mm (40)		6.2%		.425 mm (40)	26.6	16.0%	61.8%
.250 mm (60)		3.7%		.250 mm (60)	15.9	9.6%	52.2%
.180 mm (80)		1.8%		.180 mm (80)	7.8	4.7%	47.5%
.150 mm (100)		1.3%		.150 mm (100)	5.8	3.5%	44.0%
.075 mm (200)		4.6%		.075 mm (200)	19.8	11.9%	32.1%
Total	5640			Total	166.1		

21. Determine the percent passing for the -No. 10 (2.00 mm) material of the total sample. Again, by subtracting the percent retained from the percent passing the next larger sieve, we obtain the percent passing. This process is repeated for each sieve until the percent passing the No. 200 (75 μm) is obtained. All calculations should be recorded to the nearest 0.1 percent. For a quick check of your computations, remember that the percent retained and the percent passing the -No. 200 (75μm) sieve of the total sample should agree within 0.1 percent.

MECHANICAL ANALYSIS OF TOTAL SAMPLE			
SIEVE SIZES	GRAMS RETAINED	PERCENT RETAINED	PERCENT PASSING
63.0 mm (2 ½)			
50.0 mm (2)			
37.5 mm (1 ½)			100.0%
25.0 mm (1)	1155	20.5%	79.5%
19.0 mm (¾)	470	8.3%	71.2%
9.50 mm (¾)	860	15.2%	56.0%
4.75 mm (4)	540	9.6%	46.4%
2.0 mm (10)	445	7.9%	38.5%
.850 mm (20)		8.5%	30.0%
.425 mm (40)		6.2%	23.8%
.250 mm (60)		3.7%	20.1%
.180 mm (80)		1.8%	18.3%
.150 mm (100)		1.3%	17.0%
.075 mm (200)		4.6%	12.4%
Total	5640		

% Passing - % Retained = % Passing

NOTE: 100% is always placed in the percent passing column one line above the screen having the first entry of grams retained.

$$38.5 - 8.5 = 30.0$$

$$30.0 - 6.2 = 23.8$$

$$23.8 - 3.7 = 20.1$$

$$20.1 - 1.8 = 18.3$$

$$18.3 - 1.3 = 17.0$$

$$17.0 - 4.6 = 12.4$$

MECHANICAL ANALYSIS OF TOTAL SAMPLE				MECHANICAL ANALYSIS OF SOIL MORTAR			
SIEVE SIZES	GRAMS RETAINED	PERCENT RETAINED	PERCENT PASSING	SIEVE SIZES	GRAMS RETAINED	PERCENT RETAINED	PERCENT PASSING
63.0 mm (2 ½)				63.0 mm (2 ½)			
50.0 mm (2)				50.0 mm (2)			
37.5 mm (1 ½)			100.0%	37.5 mm (1 ½)			
25.0 mm (1)	1155	20.5%	79.5%	25.0 mm (1)			
19.0 mm (3/4)	470	8.3%	71.2%	19.0 mm (3/4)			
9.50 mm (3/8)	860	15.2%	56.0%	9.50 mm (3/8)			
4.75 mm (4)	540	9.6%	46.4%	4.75 mm (4)			
2.0 mm (10)	445	7.9%	38.5%	2.0 mm (10)			100.0%
.850 mm (20)		8.5%	30.0%	.850 mm (20)	36.9	22.2%	77.8%
.425 mm (40)		6.2%	23.8%	.425 mm (40)	26.6	16.0%	61.8%
.250 mm (60)		3.7%	20.1%	.250 mm (60)	15.9	9.6%	52.2%
.180 mm (80)		1.8%	18.3%	.180 mm (80)	7.8	4.7%	47.5%
.150 mm (100)		1.3%	17.0%	.150 mm (100)	5.8	3.5%	44.0%
.075 mm (200)		4.6%	12.4%	.075 mm (200)	19.8	11.9%	32.1%
Total	5640			Total	166.1		

Atterberg Limits
Liquid and Plastic Limit Tests

Liquid Limit

Definition: The amount of water (percent of moisture) that it takes for a soil to pass from a plastic to a liquid state.

The Atterberg Limits provide a measure of the consistency of the soil. With the gradation test completed, we now return to the small sample that has been drying at a maximum of 140°F (60°C). From this sample we must obtain the -No. 40 (-425 µm) material on which the Liquid Limit and Plastic Limit will be run. VDOT uses the procedure outlined in AASHTO T-89 Method B, except as modified by VTM-7, to perform routine liquid limit tests. AASHTO T-89 Method A except as modified by VTM-7 is used for referee testing.

The modification to the test method regards the sensitivity of the balance used. AASHTO T-89 requires that the balance conform to M 231, Class G1. A Class G1 balance has a readability of 0.01 grams. VTM- 7 states that a balance with a sensitivity of 0.10 grams may be used.

The steps for the tests procedures are outlined as follows:

1. Buff and sieve the entire sample using a No. 10 (2.00 mm) sieve. Buff the sample using the same procedure as outlined for the gradation sample. The material retained on the No. 10 (2.00 mm) sieve may be discarded.
2. Buff and sieve a representative sample of the material passing the No. 10 (2.00 mm) sieve using a No. 40 (425 µm) sieve with a sieve pan under it. Again use the same procedure for buffing as outlined for the gradation sample. The material retained on the No. 40 (425 µm) sieve should be rebuffered and resieved until little or no material is passing the No. 40 (425 µm) sieve. The No. -40 (-425 µm) material is used for the Atterberg Limits.
3. The Liquid Limit device should be inspected to determine that the device is in good working order. There should be no excessive wear in the pin connecting the cup, nor a groove cut in the cup through long usage. The Liquid Limit Cup should be inspected for proper thickness. The grooving tool should be inspected to determine if there is excessive wear on the cutting edge. It is essential that the Liquid Limit cup be adjusted so that, when it is raised, the contact point of the cup is 10.0 mm ± 2 mm above the base (the back end of the grooving tool is 10.0 mm in thickness). The adjustment plate is manipulated back and forth by loosening the screws in its tip and turning the set screw at the back. With the 10.0 mm gauge held in place, the adjustment plate is moved so that when the crank is revolved, there is a slight ringing sound when the cam strikes the cam follower. If the cup is raised off the gauge or no sound is heard, further adjustments are necessary.
4. Obtain a sample weighing approximately 50 grams from the thoroughly mixed portion of the material passing the No. 40 (425 µm) sieve. Place this material in a mixing dish and mix with 8-10 ml of distilled or demineralized water. The material is mixed by alternately and repeatedly stirring, kneading, and chopping with a spatula. If additional water is needed in the mixture, it shall be added increments of 1-3 ml. It shall then be thoroughly mixed in

the soil as previously described. Add sufficient water to the soil to form a uniform mass of stiff consistency.

NOTE: The cup of the Liquid Limit device shall not be used for mixing soil and water.

5. Place a portion of this mixture in the cup of the Liquid Limit device above the spot where the cup rests on the base and, with a spatula, squeeze and spread the material with as few strokes as possible. The material is then leveled and at the same time trimmed to a depth of 1/2 inch (1.0 cm) at the point of maximum thickness.
6. Divide the soil in the cup by firm strokes of the grooving tool along a diameter of the centerline of the cam follower. To avoid tearing the side of the groove or slipping the soil cake on the cup, up to six (6) strokes may be permitted to form this groove. A stroke is considered one motion from back-to-front or front-to-back. The depth of the groove shall be increased with each stroke, and only the last stroke shall scrape the bottom of the cup.

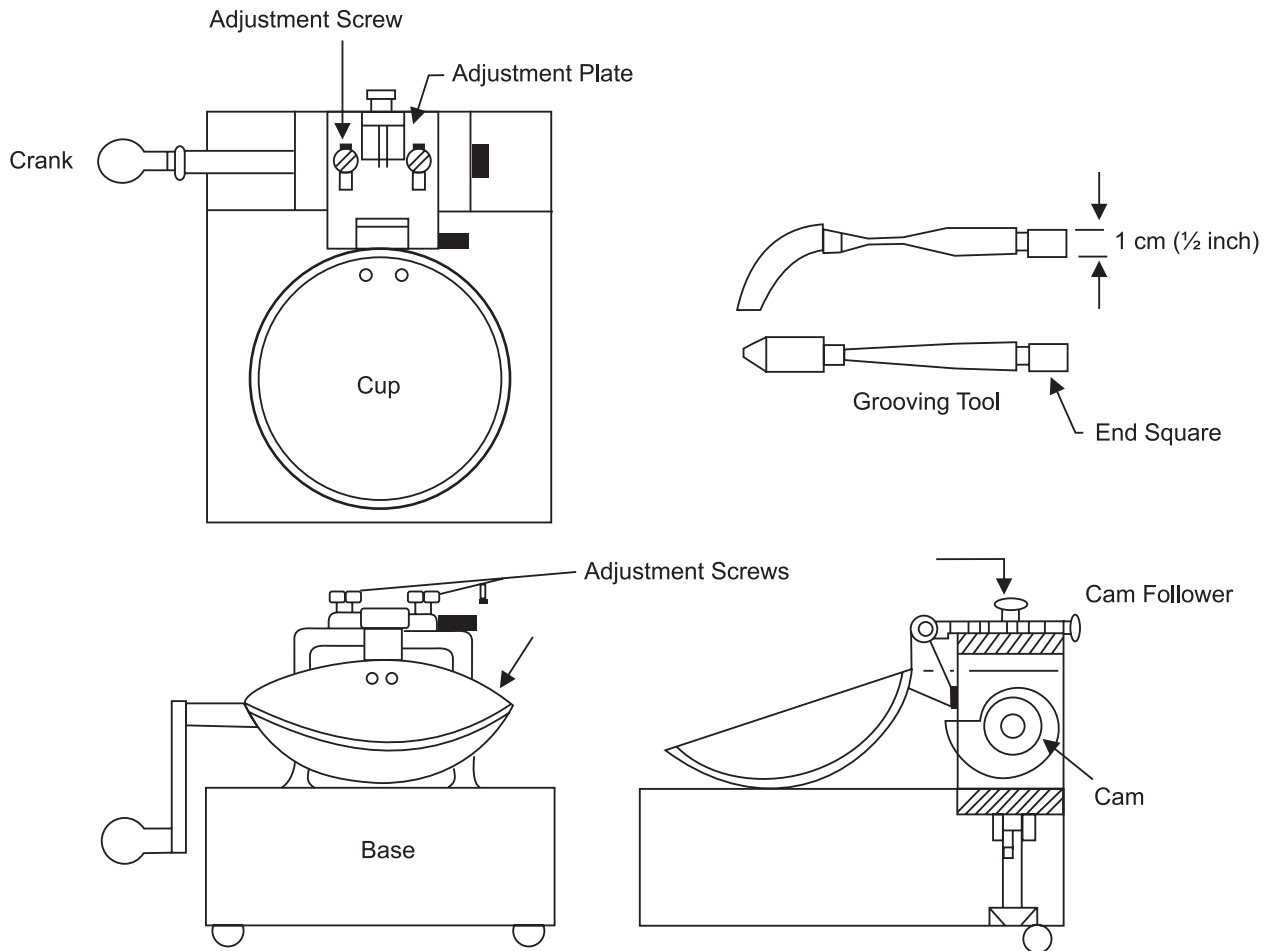

Manual Liquid Limit Device

7. The cup containing the soil sample shall be lifted and dropped by turning the crank at the rate of two (2) revolutions per second until the two sides of the sample make contact at the bottom of the groove along a distance of about 1/2 inch (12.5 mm) . The groove must be closed between 22 and 28 blows. If the closure is met between the required blows, remove the material from the cup and return it to the bowl. Do not add any additional water. Repeat steps 5 and 6. If the second closure is between 22 and 28 blows and within 2 blows of the first closure record the number as directed in step 8.

If the groove closes before 22 blows, the material is too wet and must be discarded. It will be necessary to restart the test. If it takes more than 28 blows to close the groove, the material is too dry. It is permitted to return this material to the mixing dish, add a small increment of water and remix thoroughly.

NOTE: While the crank is being turned, the base of the machine should not be held.

8. Record the number of blows to close the groove 1/2 inch (12.5 mm) on the worksheet in the “Liquid Limit Section”.
9. Remove and place in a suitable container with a close-fitting lid, a slice of soil approximately the width of the spatula (3/4 inch) extending from edge-to-edge of the soil cake, and at right angles to the portion of the groove in which the soil flows together. The covered container and the soil shall then be weighed and the weight recorded on the form. The weight should be recorded to the nearest 0.1 gram.

NOTE: The weight of the empty container and lid should already be recorded on the form in the space marked “Dish”.

10. Dry the soil in the container to a constant weight at $230 \pm 9^\circ\text{F}$ ($110 \pm 5^\circ\text{C}$) and record the weight of the covered container and dry soil. Again, the weight should be recorded to the nearest 0.1 gram.

Liquid Limit	
Dish No. 160	No. of Blows 28
Dish & Wet Soil 42.4	Dish & Dry Soil 38.6
Dish & Dry Soil 38.6	Dish 19.4
Mass of Water	Dry Soil
$\% \text{ Moisture} = \frac{\text{Mass of Water}}{\text{Dry Soil}} \times 100 =$	
L.L. =	

Liquid Limit Chart

$$L. L. = M(f)$$

Where : L. L. = Liquid Limit

M = % Moisture

f = Correction Factor

N = Number of Blows

N	f
15	0.940
16	0.947
17	0.954
18	0.961
19	0.967
20	0.973
21	0.979
22	0.985
23	0.990
24	0.996
25	1.000
26	1.005
27	1.009
28	1.014
29	1.018
30	1.022
31	1.026
32	1.030
33	1.034
34	1.038
35	1.042
36	1.045
37	1.049
38	1.052
39	1.055
40	1.059

Example : % Moisture at 22 blows = 42.3

From Table for 22 blows, f = 0.985

$$L. L. = 42.3 \times 0.985$$

$$L. L. = 41.7$$

11. Calculate the Liquid Limit of the material. First we must determine the weight of the water. To determine the weight of the water, we must subtract the weight of the dish and dry soil from the weight of the dish and wet soil. Record the weight of the water on the form in the space marked “Mass of Water”
12. Secondly, we must determine the weight of the dry soil. To determine the weight of the dry soil, we must subtract the weight of the dish from the weight of the dish and dry soil. Record the weight of the dry soil on the form in the space marked “Dry Soil”.
13. We are now ready to calculate the percent moisture or limit at which the soil becomes liquid. To determine the percent of moisture, we divide the weight of the water by the weight of the dry soil and multiply by “100”. Record this in the space marked “% Moisture”. Since our Liquid Limit Test is based on a standard of 25 blows to close the groove, and if we had a number other than 25, we must use a factor to convert the moisture to what it would have been if the groove had closed at 25 blows.

A chart of correction factors is supplied to all pugmill laboratories (See page 3-17). By multiplying the percent of moisture by the correction factor, we determine the true Liquid Limit. The Liquid Limit is reported and recorded to the nearest 0.1 gram on the form.

$$\begin{array}{r} (1) \\ 42.4 \\ - 38.6 \\ \hline 3.8 \end{array}$$

$$\begin{array}{r} (2) \\ 38.6 \\ - 19.4 \\ \hline 19.2 \end{array}$$

Liquid Limit	
Dish No. 160	No. of Blows 28
Dish & Wet Soil 42.4	Dish & Dry Soil 38.6
Dish & Dry Soil 38.6	Dish 19.4
Mass of Water 3.8	Dry Soil 19.2
% Moisture = $\frac{\text{Mass of Water} \times 100}{\text{Dry Soil}} = \frac{3.8 \times 100}{19.2} = 19.8$	
L.L. = 20.1	

$$(3) \% \text{ Moisture} = \frac{3.8}{19.2} \times 100 = 19.8$$

$$(4) \text{ L.L.} = 19.8 \times 1.014 \text{ (factor for 28 blows)}$$

$$\text{L.L.} = 20.1$$

Plastic Limit

Definition: The amount of water (percent of moisture) that it takes for a soil to pass from a semi-solid to a plastic state.

VDOT uses the procedure outlined in AASHTO T-90, except as modified by VTM-7, to perform determine the plastic limit and plasticity index of soils. The modification to the test method regards the sensitivity of the balance used. AASTHO T-90 requires that the balance conform to M 231, Class G1. A Class G1 balance has a readability of 0.01 grams. VTM- 7 states that a balance with a sensitivity of 0.10 grams may be used.

1. To determine the plastic limit, remove an 8-gram portion of the thoroughly mixed material that is to be used for the liquid limit test. The sample may be removed at any time after the material becomes plastic enough to be easily shaped into a ball without sticking excessively to the fingers when squeezed, or at the completion of the liquid limit test.
2. From the 8-gram mass of mixed material, break off a 1.5 - 2.0 gram portion. Squeeze and form the sample into an ellipsoidal-shaped mass and roll this mass between the fingers and a piece of glass or unglazed paper lying on a smooth horizontal surface, with just enough pressure to roll the mass into a thread of uniform diameter throughout its length. The rate of rolling shall be between 80 and 90 strokes per minute, counting a stroke as one complete motion of the hand forward and back to the starting position. This operation shall continue until the thread becomes 1/8 inch (3.0 mm) in diameter. At no time shall the operator attempt to produce failure at exactly 1/8 inch (3.0 mm) by either reducing the rate of rolling or increasing the pressure. If a sample cannot be rolled to a thread of 1/8 inch (3.0 mm) on the first attempt, it shall be considered non-plastic and no further testing is necessary. Record NP for non-plastic under "Plastic Limit".
3. Should the sample roll down to 1/8 inch (3.0 mm), break the thread into 6 to 8 pieces and squeeze the pieces together between the thumb and fingers of both hands. Again, shape the material into a uniform mass roughly ellipsoidal shaped and re-roll. Continue this alternate rolling to a thread 1/8 inch (3.0 mm) in diameter, gathering together, kneading, and re-rolling until the thread crumbles under pressure required for rolling the soil no longer can be rolled into a thread. The crumbling may occur when the thread is of a diameter greater than 1/8 inch (3.0 mm). This shall be considered a satisfactory end point, provided this has previously been rolled into a 1/8 inch (3.0 mm) thread. The crumbling will manifest itself differently with the various types of soils. Repeat steps 2 and 3 until the 8-gram portion of material is completely tested.

- At the conclusion of the rolling when the sample has finally crumbled, gather the soil, place in a suitable container with a close-fitting lid and weigh. This weight must be recorded to the nearest 0.1 gram on the form in the space marked “Dish & Wet Soil”.

NOTE: The weight of the empty container and lid should already be recorded on the form in the space marked “Dish”.

- Dry the soil in the container to a constant weight at $230 \pm 9^\circ\text{F}$ ($110 \pm 5^\circ\text{C}$) and re-weigh. Record the weight in the space marked “Dish and Dry Soil”. Again, the weight must be recorded to the nearest 0.1 gram.

Plastic Limit	
Dish No. 136	
Dish & Wet Soil 36.1	Dish & Dry Soil 33.7
Dish & Dry Soil 33.7	Dish 20.0
Mass of Water	Dry Soil
P. L. = $\frac{\text{Mass of Water}}{\text{Dry Soil}} \times 100 = \underline{\hspace{2cm}}$	

- Calculate the Plastic Limit of the Material. First, we must determine the mass of the water. To determine the weight of the water, we must subtract the weight of the dish and dry soil from the weight of the dish and wet soil. Record the weight of the water on the form in the space labeled, **Mass of Water**.

Secondly, as for the Liquid Limit, we must determine the weight of the dry soil. To determine the weight of the dry soil, we must subtract the weight of the dish from the weight of the dish and dry soil. Record the weight in the space labeled **Dry Soil** on the form.

We are now ready to calculate the percent of moisture or limit at which the soil becomes plastic. To determine the percent moisture, we divide the weight of the water by the weight of the dry soil and multiply by “100”. **A conversion factor is not needed to compute the Plastic Limit.**

$$\begin{array}{r}
 (1) \\
 36.1 \\
 - 33.7 \\
 \hline
 2.4
 \end{array}$$

Plastic Limit			
Dish No. 136			
Dish & Wet Soil	36.1	Dish & Dry Soil	33.7
Dish & Dry Soil	33.7	Dish	20.0
Mass of Water	2.4	Dry Soil	13.7
P. L. = $\frac{\text{Mass of Water}}{\text{Dry Soil}} \times 100 = \underline{17.5}$			

$$\begin{array}{r}
 (1) \\
 36.1 \\
 - 33.7 \\
 \hline
 2.4
 \end{array}$$

$$(3) \text{ Plastic Limit} = \frac{2.4}{13.7} \times 100 = 17.5$$

Plasticity Index

Definition: The numerical difference between the Liquid Limit and the Plastic Limit, we simply subtract the Plastic Limit from the Liquid Limit. If a material is non-plastic, the Plastic Limit is recorded as 0.0.

Liquid Limit	20.1%
Plastic Limit	<u>17.5%</u>
Plasticity Index	2.6%

Optimum Moisture Dense Graded Aggregates

Optimum moisture content is defined as the water content at which an aggregate mixture will achieve maximum density for a particular compaction method. Even with an understanding of the definition of optimum moisture as stated above, the words optimum moisture have little meaning to a Producer Technician or Inspector unless a measurable value can be found to express optimum moisture. The American Association of State Highway and Transportation Officials (**AASHTO**) has adopted a laboratory test method to determine the optimum moisture content of aggregate mixtures. Like other moisture contents, optimum moisture is expressed as a percentage.

It is not necessary for the Producer Technician or Inspector to understand the laboratory test method or memorize the test procedure. However, it is very important that they understand the laboratory test results as reported and how they apply to the production and inspection of central-mix mixtures.

A moisture content of optimum moisture plus or minus two (2) percentage points is required by the Virginia Department of Transportation Road and Bridge Specifications in the production of central-mix aggregate mixtures. With this requirement, a need arises for the Producer Technician and Inspector to understand some of the descriptive terms used in referring to optimum moisture.

Some of the descriptive terms used are:

- (a) Plus 4 material (4.75 mm) - All the material in an aggregate mixture retained on the #4 (4.75 mm) sieve.
- (b) Minus 4 material (4.75 mm) - All the material in an aggregate mixture passing the #4 (4.75 mm) sieve.
- (c) Minus 4 (4.75 mm) optimum moisture - optimum moisture of the minus 4 (4.75 mm) material is determined by District Laboratory proctor test (AASHTO T-99).
- (d) Plus 4 (4.75 mm) optimum moisture - Optimum moisture of the plus 4 (4.75 mm) material is one percent (1%) of the percentage of the plus 4 (4.75 mm) material, or as directed by the Engineer.
- (e) Absorption - Percent of moisture in an aggregate in a saturated surface dry condition (SSD).
- (f) Total optimum moisture - The sum of the weighted optimum moistures of the minus 4 (4.75 mm) material and plus 4 (4.75 mm) material.
- (g) Moisture Range - Total optimum moisture plus or minus two (2) percentage points.

The laboratory test method as adopted by AASHTO to determine optimum moisture utilizes only the minus 4 (4.75 mm) portion of an aggregate mixture and may be reported as that of the minus 4 (4.75 mm) material only. We have seen that in all specification dense graded aggregate that we must have a percentage of +4 (+4.75 mm) material. Therefore, it becomes necessary for the Producer Technician to calculate the total optimum moisture for a particular central-mix aggregate mixture.

Regardless of the particular type of central-mix aggregate mixture, the procedure for calculating the total optimum moisture and determining the moisture range is the same. The procedure is outlined as follows:

Step 1. Obtain the required data.

- a. The percentage of minus -No. 4 (4.75 mm) material in the aggregate mixture must be obtained. This information is obtained from the mechanical analysis of total sample.

Example:

<u>Sieve Sizes</u>	<u>Percent Passing</u>
-No. 4(-4.75 mm) +No. 10(+2.00 mm)	46.4

- b. The percentage of plus No. 4 (4.75 mm) material in the aggregate mixture must be obtained. This is obtained by subtracting the percentage of minus No. 4 (4.75 mm) material in the aggregate mixture from 100.

Example: $100.0 - 46.4 = 53.6$

- c. The optimum moisture of the minus -No. 4 (4.75 mm) and the absorption of the material must be obtained. This information is obtained from the District Materials Engineer.

Example: **Optimum Moisture - 10.5%** **Absorption - 0.3%**

- d. The optimum moisture of the +No. 4 (+4.75 mm) material, as previously stated, is one percent (1%) of the percentage of +No. 4 (+4.75 mm) material, or as directed by the Engineer.

Step 2. Calculate the total optimum moisture content and determine the moisture range of the aggregate mixture.

Example:

Size Material	% Material Expressed as a Decimal	Moisture	Calculated Weighted Average
-No. 4 (-4.75 mm)	0.464	x 10.5	= 4.872 or 4.9%
+ No. 4 (+4.75 mm)	0.536	x (0.3 + 1)	=
	0.536	x 1.3	= 0.696 or + <u>0.7%</u>

Total Optimum Moisture = 5.6%

Moisture Range	<u>5.6</u> <u>- 2.0</u> 3.6 %	to	<u>5.6</u> <u>+ 2.0</u> 7.6%
----------------	--	----	---

Gradation Worksheet

MECHANICAL ANALYSIS OF TOTAL SAMPLE				MECHANICAL ANALYSIS OF SOIL MORTAR			
SIEVE SIZES	GRAMS RETAINED	PERCENT RETAINED	PERCENT PASSING	SIEVE SIZES	GRAMS RETAINED	PERCENT RETAINED	PERCENT PASSING
63.0 mm (2 ½)		%		63.0 mm (2 ½)		%	
50.0 mm (2)		%		50.0 mm (2)		%	
37.5 mm (1 ½)		%	100.0%	37.5 mm (1 ½)		%	
25.0 mm (1)	1155	20.5%	79.5%	25.0 mm (1)		%	
19.0 mm (3/4)	470	8.3%	71.2%	19.0 mm (3/4)		%	
9.50 mm (3/8)	860	15.2%	56.0%	9.50 mm (3/8)		%	
4.75 mm (4)	540	9.6%	46.4%	4.75 mm (4)		%	
2.0 mm (10)	445	7.9%	38.5%	2.0 mm (10)		%	100.0%
.850 mm (20)		8.5%	30.0%	.850 mm (20)	36.9	22.2%	77.8%
425 mm (40)		6.2%	23.8%	425 mm (40)	26.6	16.0%	61.8%
.250 mm (60)		3.7%	20.1%	.250 mm (60)	15.9	9.6%	52.2%
.180 mm (80)		1.8%	18.3%	.180 mm (80)	7.8	4.7%	47.5%
.150 mm (100)		1.3%	17.0%	.150 mm (100)	5.8	3.5%	44.0%
.075 mm (200)		4.6%	12.4%	.075 mm (200)	19.8	11.9%	32.1%
Total	5640	12.4%		Total	166.1	32.1%	

Liquid Limit		Plastic Limit		Physical Characteristics of Soil	
Dish No. 160	No. of Blows 28	Dish No. 136		Liquid Limit	20.1 %
Dish & Wet Soil 42.4	Dish & Dry Soil 38.6	Dish & Wet Soil 36.1	Dish & Dry Soil 33.7	Plastic Limit	17.5 %
Dish & Dry Soil 38.6	Dish 19.4	Dish & Dry Soil 33.7	Dish 20.0	Plasticity Index	2.6 %
Mass of Water 3.8	Dry Soil 19.2	Mass of Water 2.4	Dry Soil 13.7		
% Moisture = $\frac{\text{Mass of Water} \times 100}{\text{Dry Soil}} = \underline{\underline{19.8}}$		P.L. = $\frac{\text{Mass of Water} \times 100}{\text{Dry Soil}} = \underline{\underline{17.5}}$		Optimum Moisture Content	
L.L. = <u>20.1</u>				Total Soil	%
				-4.75 mm (-4) Portion	10.5 %
				Maximum Density	
				Total Soil	kg/m ³ (lbs/ft ³)
				-4.75 mm (-4) Portion	kg/m ³ (lbs/ft ³)

Wet Weight = 5922 grams % Moisture = 5.0 Moisture Range 3.6 – 7.6 Absorption 0.3

Percent Moisture	Percent Optimum Moisture	
$\frac{5922 \text{ wet wt.} - 5640 \text{ dry wt.}}{282}$ $\frac{282}{5640} = 0.05 \times 100 = \mathbf{5.0\% \text{ moisture}}$	-No. 4 (-4.75) optimum moisture $\frac{0.464}{\times 10.5}$ $4.872 = \mathbf{4.9\%}$	+No. 4 (+4.75) optimum moisture $\frac{0.536}{\times 1.3 (0.3 + 1)}$ $0.696 = \mathbf{0.7\%}$
Percent +No. 4 (+4.75)	Total Optimum Moisture	Moisture Range
100.0 $- 46.4 \text{ -No. 4 (-4.75)}$ $\mathbf{53.6 \text{ +No. 4 (+4.75)}}$	4.9% $+ 0.7\%$ $\mathbf{5.6\%}$	$5.6\% \quad 5.6\%$ $- 2.0\% \quad + 2.0\%$ $\mathbf{3.6\% \text{ to } 7.6\%}$

Chapter 3
Sampling and Testing Aggregates
Study Questions

1. The fine gradation is washed over the:
 - A. No. 10 (2.00 mm) sieve
 - B. No. 40 (425 μm) sieve
 - C. No. 100 (150 μm) sieve
 - D. No. 200 (75 μm) sieve

2. The sieve size that separates the coarse material from the fine material is the:
 - A. No. 40 (425 μm) sieve
 - B. No. 10 (2.00 mm) sieve
 - C. No. 80 (180 μm) sieve
 - D. No. 100 (150 μm) sieve

3. The fine gradation sample should weigh between:
 - A. 75 and 100 grams
 - B. 100 and 125 grams
 - C. 125 and 200 grams
 - D. 200 and 300 grams

4. A process in which an aggregate is separated into its various sizes by passing it through screens of various openings for the purpose of determining the distribution of the quantities separated is:
 - A. Fineness Modulus
 - B. Sieve analysis
 - C. Moisture analysis
 - D. Yield

5. The minimum dry weight of a sample of central mix aggregate that contains +19.0 mm (3/4 inch) material should be:
 - A. 2000 grams
 - B. 4000 grams
 - C. 5000 grams
 - D. 8000 grams

Chapter 3
Sampling and Testing Aggregates
Study Questions

6. Two acceptable ways of splitting a sample are by a sample splitter and by the quartering method.
- A. True
 - B. False
7. What is the temperature range at which the fine gradation is dried?
8. The fine material is shaken for how many minutes?
9. The total sample is computed to the nearest _____ percent?
10. The numerical difference between the liquid limit and plastic limit is the plasticity index.
- A. True
 - B. False
11. The liquid limit and plastic limit tests are run on material passing the:
- A. No. 10 (2.00 mm) sieve
 - B. No. 40 (425 μm) sieve
 - C. No. 80 (180 μm) sieve
 - D. No. 200 (75 μm) sieve
12. The moisture content at which a soil changes from a semi-solid to a plastic state is the liquid limit.
- A. True
 - B. False
13. In determining the liquid limit and plastic limit, the portion of the wet sample used must be dried at a temperature not to exceed 140°F (60°C) .
- A. True
 - B. False

Chapter 3
Sampling and Testing Aggregates
Study Questions

16. What are the requirements for water used in the liquid limit and plastic limit test?
17. How many blows per second is the cup on the liquid limit device dropped?
18. To determine the moisture content in the liquid limit test a slice of soil approximately the width of the spatula extending from edge to edge of the soil cake at right angles to the groove, and including that portion that flowed together must be taken. True or False?
19. When determining the plastic limit, the soil is rolled to a thread of ____.
20. VDOT Specifications require that Central Mixed Aggregate be shipped at optimum moisture \pm __ percentage points.
 - A. 5
 - B. 4
 - C. 3
 - D. 2

Chapter 3
Sampling and Testing Aggregates
Problem No. 1
Moisture Calculation

Complete the following moisture determination problem and give the moisture content in percent.

Dish & Wet Material	700 grams
Dish & Dry Material	680 grams
Dish	200 grams

Problem No. 2
Moisture Calculation

In an effort to determine the moisture content of a material, a sample of the material was taken and found to weigh 1346 grams. The sample was then dried to a constant weight and reweighed. The dried sample was found to have a weight of 1240 grams. Using this information, calculate the percent of moisture.

Chapter 3
Sampling and Testing Aggregates
Study Questions
Problem No. 3

3. Below is a sample of an Aggregate Subbase Material, Type I, Grading No. 21A. Complete the worksheet for gradation, liquid limit, plastic limit, plasticity index, optimum moisture content and moisture range.

MECHANICAL ANALYSIS OF TOTAL SAMPLE				MECHANICAL ANALYSIS OF SOIL MORTAR			
SIEVE SIZES	GRAMS RETAINED	PERCENT RETAINED	PERCENT PASSING	SIEVE SIZES	GRAMS RETAINED	PERCENT RETAINED	PERCENT PASSING
63.0 mm (2 ½)		%		63.0 mm (2 ½)		%	
50.0 mm (2)		%		50.0 mm (2)		%	
37.5 mm (1 ½)		%		37.5 mm (1 ½)		%	
25.0 mm (1)		%		25.0 mm (1)		%	
19.0 mm (3/4)	252	%		19.0 mm (3/4)		%	
9.50 mm (3/8)	2352	%		9.50 mm (3/8)		%	
4.75 mm (4)	1241	%		4.75 mm (4)		%	
2.0 mm (10)	1017	%		2.0 mm (10)		%	
.850 mm (20)		%		.850 mm (20)	39.7	%	
.425 mm (40)		%		.425 mm (40)	23.2	%	
.250 mm (60)		%		.250 mm (60)	13.4	%	
.180 mm (80)		%		.180 mm (80)	9.2	%	
.150 mm (100)		%		.150 mm (100)	6.4	%	
.075 mm (200)		%		.075 mm (200)	18.8	%	
Total	9334	%		Total	174.2	%	

Liquid Limit		Plastic Limit		Physical Characteristics of Soil	
Dish No. 14	No. of Blows 26	Dish No. 19		Liquid Limit	%
Dish & Wet Soil 87.1	Dish & Dry Soil 84.1	Dish & Wet Soil 80.1	Dish & Dry Soil 78.0	Plastic Limit	%
Dish & Dry Soil 84.1	Dish 72.8	Dish & Dry Soil 78.0	Dish 69.4	Plasticity Index	%
Mass of Water	Dry Soil	Mass of Water	Dry Soil	Optimum Moisture Content	
% Moisture = $\frac{\text{Mass of Water}}{\text{Dry Soil}} \times 100 = \underline{\hspace{2cm}}$		P.L. = $\frac{\text{Mass of Water}}{\text{Dry Soil}} \times 100 = \underline{\hspace{2cm}}$		Total Soil	%
L.L. = $\underline{\hspace{2cm}}$				-4.75 mm (-4) Portion	10.3 %
				Maximum Density	
				Total Soil	kg/m ³ (lbs/ft ³)
				-4.75 mm (-4) Portion	kg/m ³ (lbs/ft ³)

Wet Weight = **9847** grams % Moisture **5.5** Moisture Range _____ Absorption = **0.3**

Chapter 3
Sampling and Testing Aggregates
Study Questions
Problem No. 4

Below is a sample of an Aggregate Subbase Material, Type I, Grading No. 21A. Complete the worksheet for gradation, liquid limit, plastic limit, plasticity index, optimum moisture content and moisture range.

MECHANICAL ANALYSIS OF TOTAL SAMPLE				MECHANICAL ANALYSIS OF SOIL MORTAR			
SIEVE SIZES	GRAMS RETAINED	PERCENT RETAINED	PERCENT PASSING	SIEVE SIZES	GRAMS RETAINED	PERCENT RETAINED	PERCENT PASSING
63.0 mm (2 ½)		%		63.0 mm (2 ½)		%	
50.0 mm (2)		%		50.0 mm (2)		%	
37.5 mm (1 ½)		%		37.5 mm (1 ½)		%	
25.0 mm (1)		%		25.0 mm (1)		%	
19.0 mm (¾)	357	%		19.0 mm (¾)		%	
9.50 mm (3/8)	1448	%		9.50 mm (3/8)		%	
4.75 mm (4)	913	%		4.75 mm (4)		%	
2.0 mm (10)	1011	%		2.0 mm (10)		%	
.850 mm (20)		%		.850 mm (20)	57.8	%	
425 mm (40)		%		425 mm (40)	24.8	%	
.250 mm (60)		%		.250 mm (60)	16.0	%	
.180 mm (80)		%		.180 mm (80)	8.7	%	
.150 mm (100)		%		.150 mm (100)	6.3	%	
.075 mm (200)		%		.075 mm (200)	19.5	%	
Total	6136			Total	190.0		

Liquid Limit		Plastic Limit		Physical Characteristics of Soil	
Dish No. 21	No. of Blows 28	Dish No. 10		Liquid Limit %	
Dish & Wet Soil 52.1	Dish & Dry Soil 48.9	Dish & Wet Soil 79.9	Dish & Dry Soil 77.8	Plastic Limit %	
Dish & Dry Soil 48.9	Dish 33.7	Dish & Dry Soil 77.8	Dish 67.4	Plasticity Index %	
Mass of Water	Dry Soil	Mass of Water	Dry Soil		
% Moisture = $\frac{\text{Mass of Water}}{\text{Dry Soil}} \times 100 = \underline{\hspace{2cm}}$		P. L. = $\frac{\text{Mass of Water}}{\text{Dry Soil}} \times 100 = \underline{\hspace{2cm}}$		Optimum Moisture Content	
L.L. = $\underline{\hspace{2cm}}$				Total Soil %	
				-4.75 mm (-4) Portion 10.5 %	
				Maximum Density	
				Total Soil kg/m ³ (lbs/ft ³)	
				-4.75 mm (-4) Portion kg/m ³ (lbs/ft ³)	

Wet Weight = 6449 grams % Moisture 5.1 Moisture Range _____ Absorption = **0.6**

Chapter 3
Sampling and Testing Aggregates
Study Questions
Problem No. 5

Below is a sample of an Aggregate Subbase Material, Type I, Grading No. 21A. Complete the worksheet for gradation, liquid limit, plastic limit, plasticity index, optimum moisture content and moisture range.

MECHANICAL ANALYSIS OF TOTAL SAMPLE				MECHANICAL ANALYSIS OF SOIL MORTAR			
SIEVE SIZES	GRAMS RETAINED	PERCENT RETAINED	PERCENT PASSING	SIEVE SIZES	GRAMS RETAINED	PERCENT RETAINED	PERCENT PASSING
63.0 mm (2 ½)		%		63.0 mm (2 ½)		%	
50.0 mm (2)		%		50.0 mm (2)		%	
37.5 mm (1 ½)		%		37.5 mm (1 ½)		%	
25.0 mm (1)		%		25.0 mm (1)		%	
19.0 mm (3/4)	267	%		19.0 mm (3/4)		%	
9.50 mm (3/8)	2650	%		9.50 mm (3/8)		%	
4.75 mm (4)	1343	%		4.75 mm (4)		%	
2.0 mm (10)	1103	%		2.0 mm (10)		%	
.850 mm (20)		%		.850 mm (20)	44.6	%	
425 mm (40)		%		425 mm (40)	28.4	%	
.250 mm (60)		%		.250 mm (60)	15.8	%	
.180 mm (80)		%		.180 mm (80)	10.2	%	
.150 mm (100)		%		.150 mm (100)	7.6	%	
.075 mm (200)		%		.075 mm (200)	21.2	%	
Total	8893			Total	200.0		

Liquid Limit		Plastic Limit		Physical Characteristics of Soil	
Dish No. 3	No. of Blows 22	Dish No. 5		Liquid Limit	%
Dish & Wet Soil 88.2	Dish & Dry Soil 85.4	Dish & Wet Soil 80.2	Dish & Dry Soil 78.2	Plastic Limit	%
Dish & Dry Soil 85.4	Dish 72.0	Dish & Dry Soil 78.2	Dish 68.1	Plasticity Index	%
Mass of Water	Dry Soil	Mass of Water	Dry Soil		
$\% \text{ Moisture} = \frac{\text{Mass of Water}}{\text{Dry Soil}} \times 100 = \underline{\hspace{2cm}}$		$\text{P. L.} = \frac{\text{Mass of Water}}{\text{Dry Soil}} \times 100 = \underline{\hspace{2cm}}$		Optimum Moisture Content Total Soil % -4.75 mm (-4) Portion 10.8 % Maximum Density _____ Total Soil kg/m ³ (lbs/ft ³) -4.75 mm (-4) Portion kg/m ³ (lbs/ft ³)	
L.L. = _____					

Wet Weight = **9418** grams % Moisture **5.9** Moisture Range _____ Absorption = **0.7**